

External view

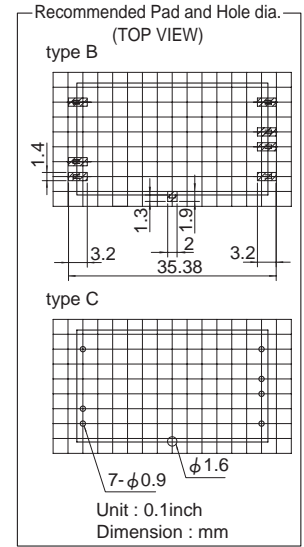

- ※ Tolerance ±0.5
- ※ Dimensions in mm
- ※ Pin terminal thickness : 0.3±0.1
- ※ Pin terminal material : Copper alloy
- ※ Plating treatment of terminal : Lead free plating
- ※ Case thickness : 0.2±0.05
- ※ Case material : Brass
- ※ Plating treatment of case : Nickel plating
- ※ Please keep enough creepage distance with the pattern on PCB and other components.
- ※ Mass 7g less

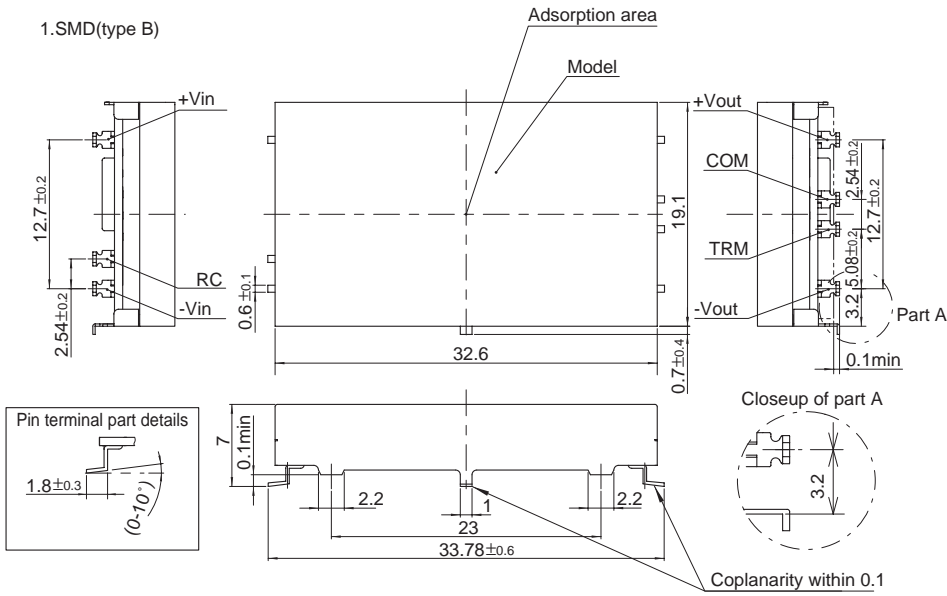