

Block diagram

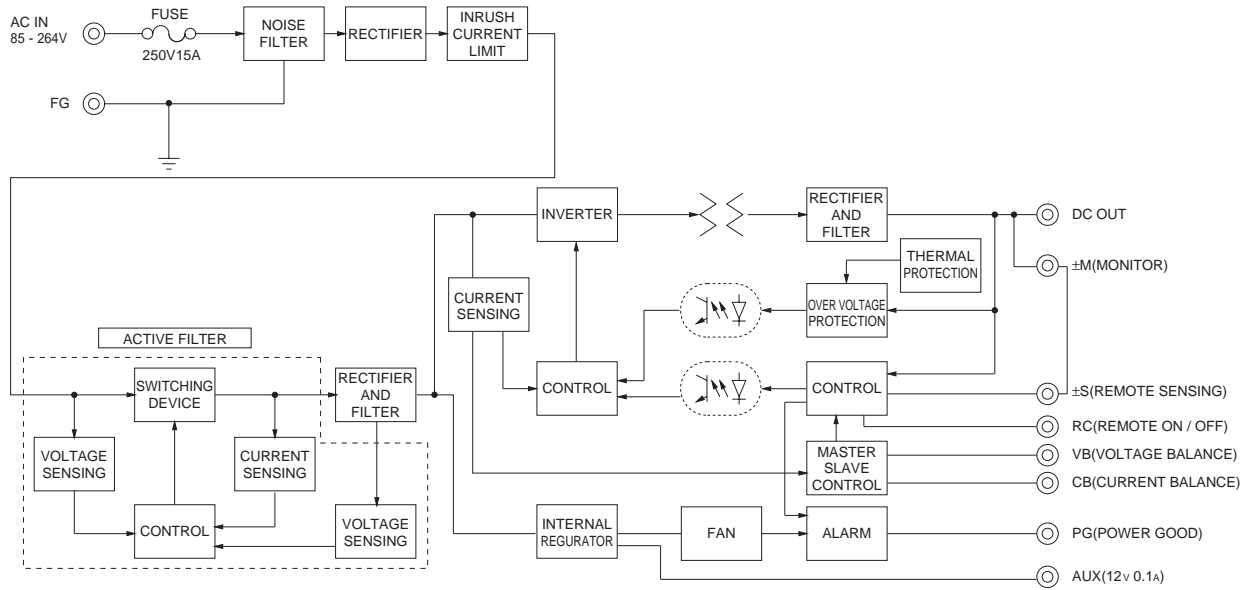

External view

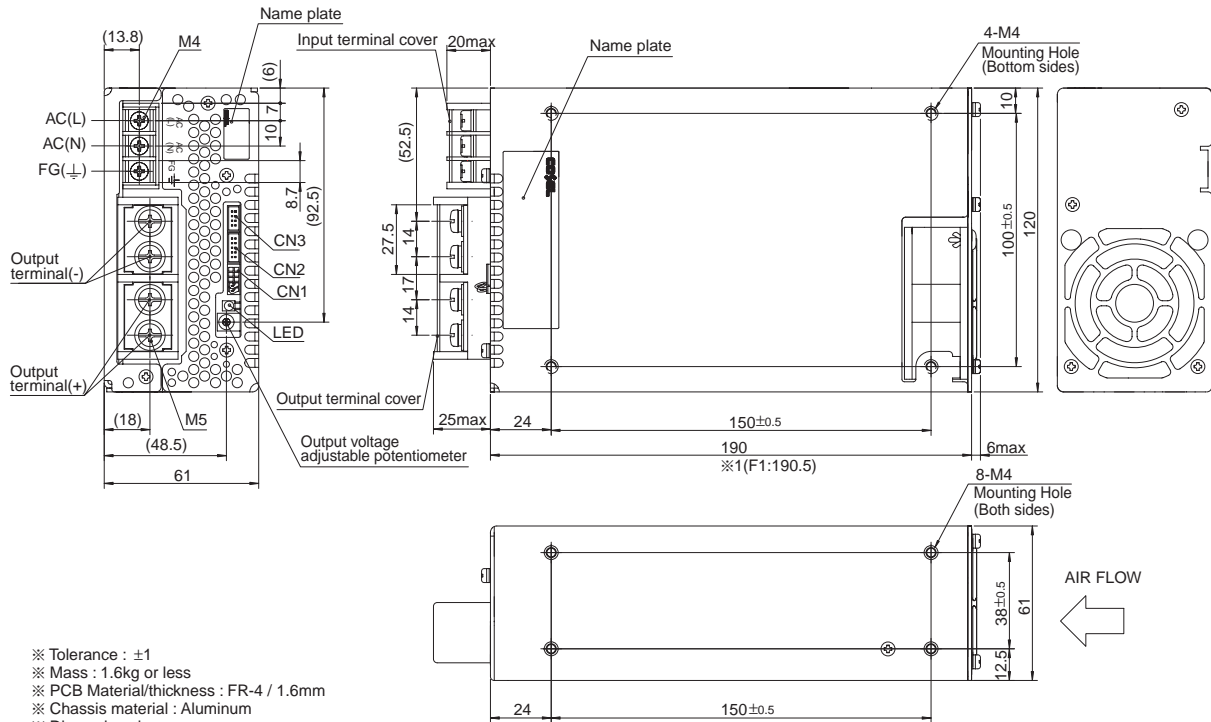

- ※ Tolerance : ±1
- ※ Mass : 1.6kg or less
- ※ PCB Material/thickness : FR-4 / 1.6mm
- ※ Chassis material : Aluminum
- ※ Dimensions in mm
- ※ Mounting torque : 1.2N · m(12.8kgf·cm)max
- ※ Screw tightening torque : M4 1.6N · m(16.9kgf · cm)max
M5 2.5N · m(24.5kgf · cm)max
- ※ The housing for the remote sensing unused is mounted on CN1
- ※ 1 F1(Optional):190.5
- ※ Please connect earth to FG terminal on the unit.