

Block diagram

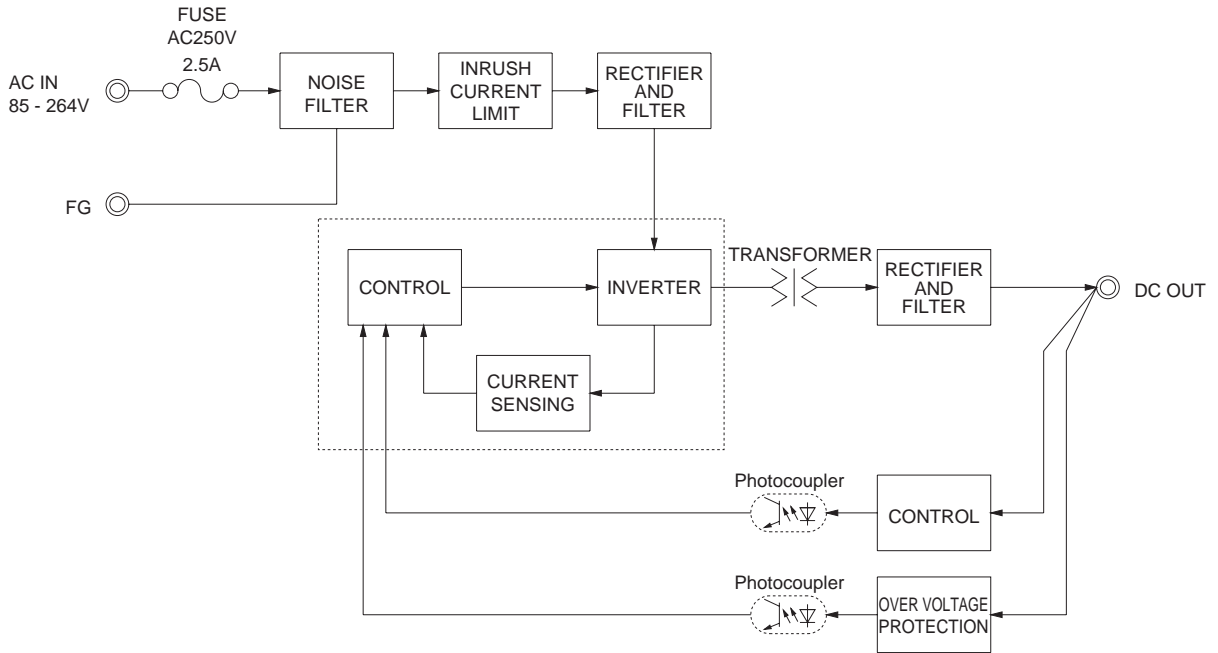

External view

※ External size of option T,J,N,N1 and V is different from standard model and refer to 7 Option of instruction manual for details.

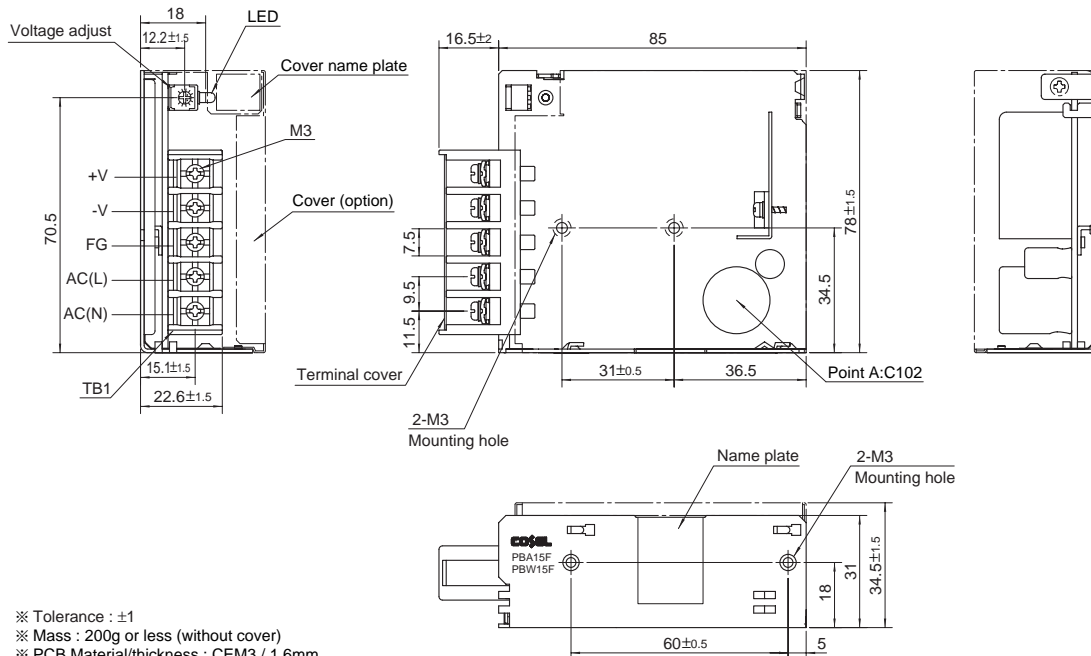

- ※ Tolerance : ±1
- ※ Mass : 200g or less (without cover)
- ※ PCB Material/thickness : CEM3 / 1.6mm
- ※ Chassis material : Electric galvanizing steel board
- ※ Dimensions in mm
- ※ Mounting torque : 0.6N • m(6.3kgf • cm)max
- ※ Screw tightening torque : M3 0.8N • m(8.5kgf • cm)max
- ※ Please connect earth to the unit in 2-M3 holes.