

Block diagram

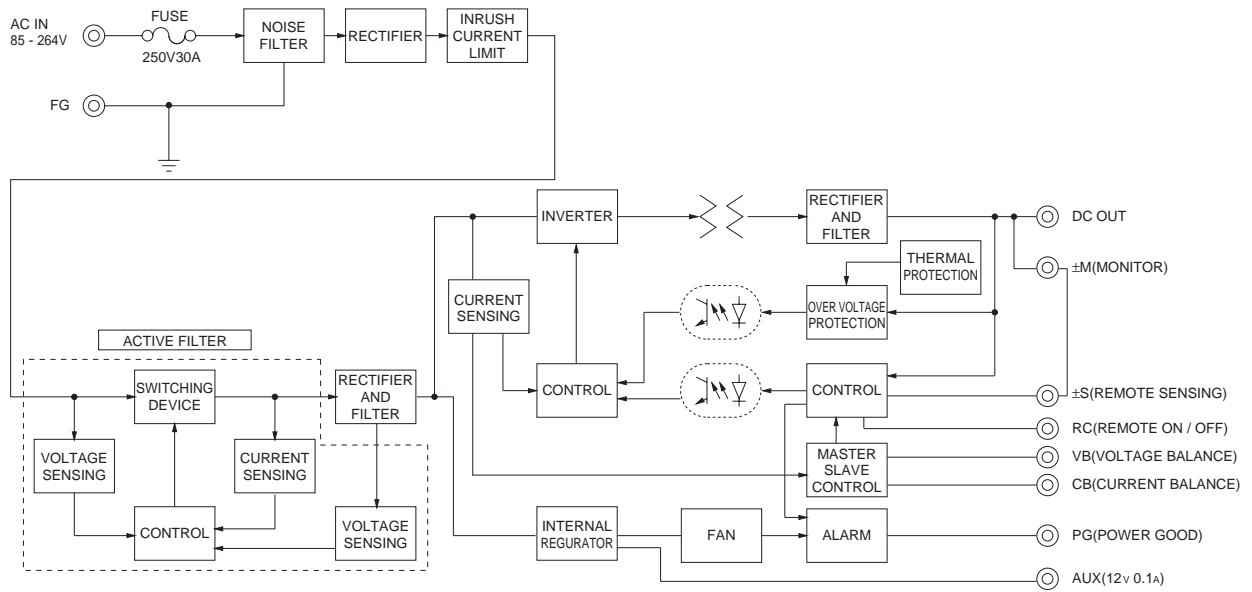

External view

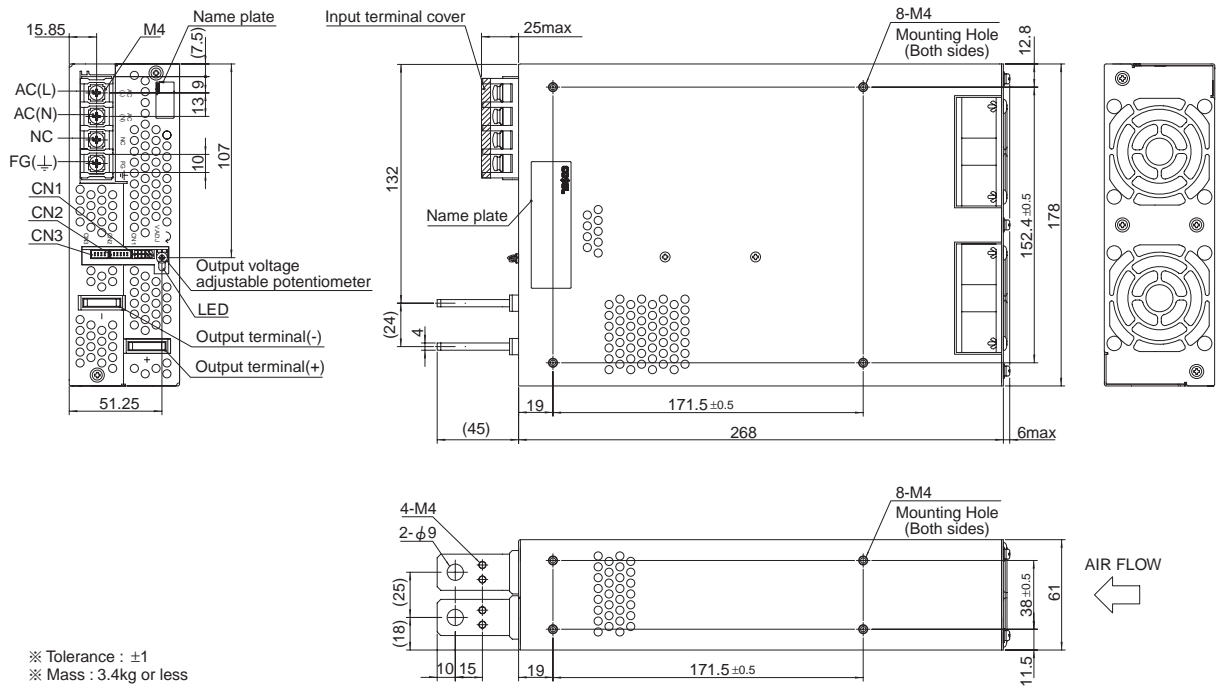

- ※ Tolerance : ± 1
- ※ Mass : 3.4kg or less
- ※ PCB Material/thickness : FR-4 / 1.6mm
- ※ Chassis material : Aluminum
- ※ Dimensions in mm
- ※ Mounting torque : $1.2N \cdot m (12.8kgf \cdot cm)$ max
- ※ Screw tightening torque : $1.6N \cdot m (16.9kgf \cdot cm)$ max
- ※ The housing for the remote sensing unused is mounted on CN1
- ※ Please connect earth to FG terminal on the unit.