

Block diagram

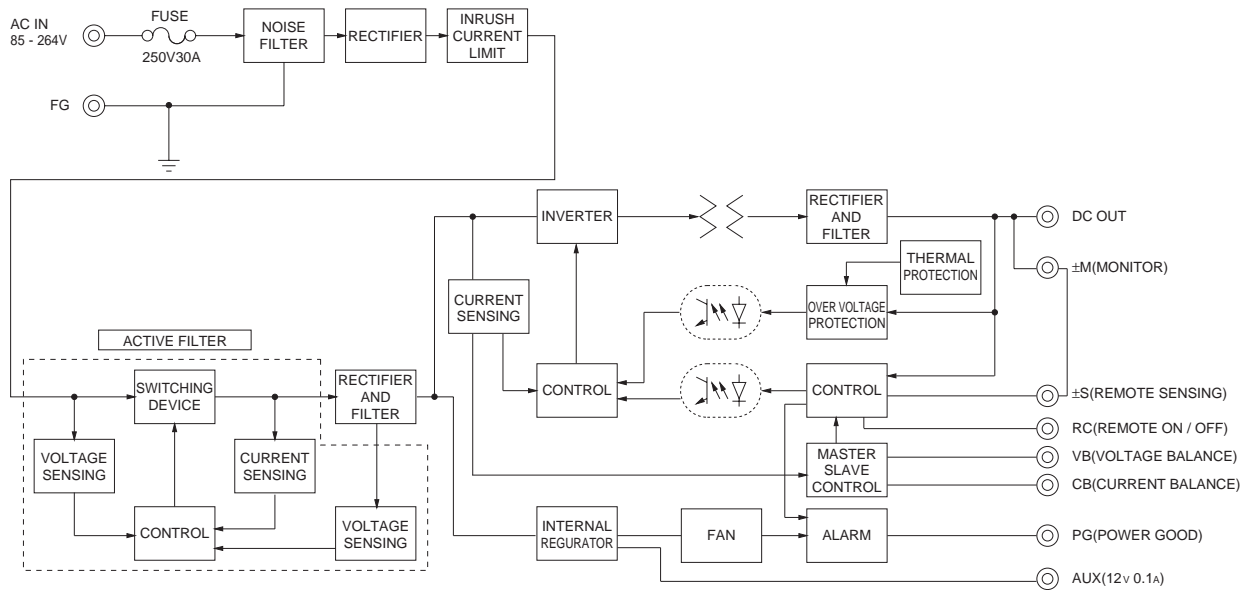

External view

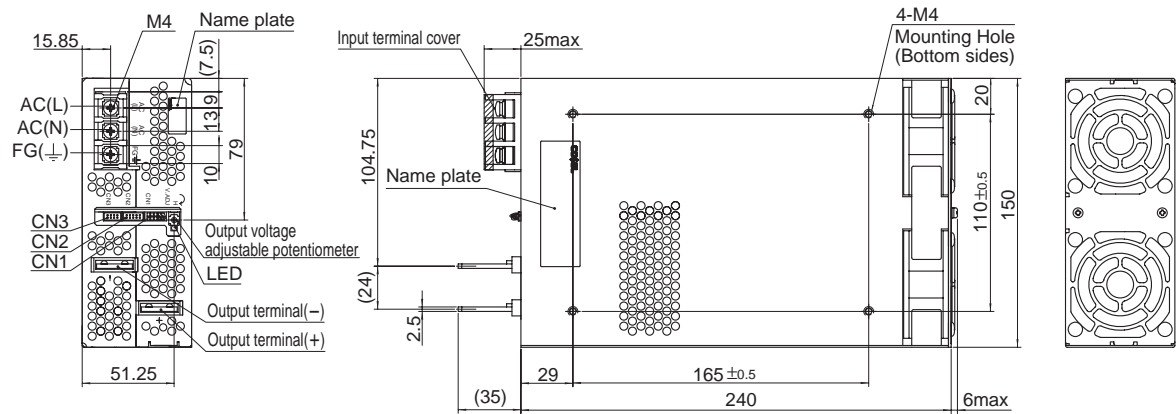

- ※ Tolerance : ±1
- ※ Mass : 2.2kg or less
- ※ PCB Material/thickness : FR-4 / 1.6mm
- ※ Chassis material : Aluminum
- ※ Dimensions in mm
- ※ Mounting torque : 1.2N • m(12.8kgf • cm)max
- ※ Screw tightening torque : 1.6N • m(16.9kgf • cm)max
- ※ The housing for the remote sensing unused is mounted on CN1
- ※ Please connect earth to FG terminal on the unit.

